

# Potomac Valley Radio Club Newsletter

March 2004

Visit us on the web at [www.pvrc.org](http://www.pvrc.org)  
and [www.pvrcnc.org](http://www.pvrcnc.org)

**PVRC welcomes Woody Kinney, KF4PLQ, and Tom Gallagher, N4IOZ to PVRCNC-West.**

## Editor's Note

By Pete Smith, N4ZR

I think we have another great issue this month, thanks to all our PVRC contributors. W3LPL provides some invaluable insights on propagation, K4QPL rises to the defense of TR Log, and K4GMH contributes his neat design for a Beverage controller, for adding to radios that don't have separate receive antenna inputs. The Toolbox and VHF columns are excellent as usual, and we have a good cross-section of news from the regional chapters.

Finally, please welcome new advertisers C3i Inc. and LZ1JZ QSL Print.

---

## PVRC Contest Calendar

**Note: All dates are Zulu, boldface denotes contests that count toward the PVRC 5 Million Award**

**ARRL International DX Contest, Phone 0000Z, Mar 6 - 2400Z, Mar 7 (starts evening of March 5 in the US)**

**Russian DX Contest 1200Z, Mar 20 - 1200Z, Mar 21**

Virginia QSO Party 1800Z, Mar 20 - 0200Z, Mar 22

**CQ WW WPX Contest, SSB 0000Z, Mar 27 - 2400Z, Mar 28 (starts evening of March 26 in the US)**

**CQ WW WPX Contest, CW 0000Z, May 29 - 2400Z, May 30 (starts evening of May 28 in the US)**

**ARRL June VHF QSO Party, 1800Z June 12 - 0300Z June 14**

IARU HF World Championship 1200Z, Jul 10 to 1200Z, Jul 11

North American QSO Party, CW 1800Z, Aug 7 to 0600Z, Aug 8

**WAE DX Contest, CW 0000Z, Aug 14 to 2359Z, Aug 15**

Maryland-DC QSO Party 1600Z, Aug 14 to 0400Z, Aug 15 and 1600Z-2359Z, Aug 15

North American QSO Party, SSB 1800Z, Aug 21 to 0600Z, Aug 22

For schedule changes, rules and log submission info, go to <http://www.hornucopia.com/contestcal/contestcal.html>

---

## From the President

By Jack Hammett, K4VV

Our Trustees and Officers had a very interesting Internet discussion about our competitiveness, with concern for declining log submissions. Some aspects of that topic are covered in the minutes of the recent northwest meeting, reported in this

newsletter. More dialogue and leadership actions will be needed.

I have seen a lot of PVRC people this month. We had a big turnout at the Central meeting for the N1MM Logger program by N4ZR. The Northwest meeting was very lively and interesting. I had the pleasure of operating with Bill, W4RM, and admiring his maturing Multi-2 station. I visited Bob, W4MYA and toured his impressive station as he reconfigures from the multiple operator configuration. I had some time with Mike, W0YR who is preparing to deploy for several years to lead a broadcasting business in eastern Europe. I had some interesting time in the car with Pete, N4ZR discussing his many projects.

We have a very diverse and talented membership. Some are building, others are trimming back, and some are moving. Some are excited by the traditional contests, and others are turned on with the wide open rush of the WPX, or the one direction focus of a Europe contest, of the weak signal challenges of the 160M or VHF/UHF contests, or on the thrill of working an expedition. Variety of interests!

The contesting column by John Dorr, K1AR in the March 2004 CQ Magazine is recommended reading. His topic is "Are We Having Fun Yet?" His point of view rings very true with me, and may be an articulate case for why our club may serve our members better by supporting and encouraging a very diverse range of contesting activities, as we seem to be doing in recent years. PVRC members are showing up in the top ranks. See the recent WPX results. We are growing stronger in VHF, in RTTY, and others. Let's celebrate our varied interests, and continue to pull together our strength for the major contests.

---

## **The Mid-Latitude Trough and its HF Propagation Effects**

**By Frank Donovan, W3LPL**

We often experience brief European openings on 40 meters at night as the solar flux drops as we approach solar cycle minimum. This same phenomenon also causes the sudden loss of propagation on the higher bands as night-time arrives over the north Atlantic and north Pacific. It also causes the disappearance of our sunrise opening to Japan on 20 meters. The loss of propagation that often (but not always) impacts north Atlantic and north Pacific night-time propagation is caused by an electron depletion region in the F layer ionosphere known as the mid-latitude trough. The mid-latitude trough is primarily a night-time phenomenon that occurs almost exclusively during the winter and the equinoxes. Summer occurrences are very rare. The pole-ward wall of the mid-latitude trough is bounded by the low-latitude boundary of the auroral region. The width of the mid-latitude trough is typically five degrees or more, extending towards the equator from its pole-ward boundary with the aurora. During the night, the equator-ward edge of the mid-latitude trough steadily drifts to lower latitudes. The mid-latitude trough disappears by re-ionization when the sun rises over that part of the ionosphere.

During the onset of increased geo-magnetic activity, the low-latitude edge of the auroral region rapidly shifts towards the equator. Consequently, the entire mid-latitude trough also shifts toward lower latitudes and propagation to Europe and Japan is likely to fail completely.

What does this mean for upcoming ARRL DX contests? 40 meter propagation to Europe on 40 meters will be best during the hours near our sunset. Propagation to northern Europe will fade away within an hour or two after sunset, and only the southern tier of Europe may be workable by as early as 0100Z. Europe will often fade away by 0200Z, except for skew paths toward the south-east and south. On many (but not all) nights, propagation will return briefly during the hours near European sunrise, as the mid-latitude trough is re-ionized by the sun. Propagation to Europe will last longer into the night in North Carolina and Virginia than it does in New Hampshire and Massachusetts. Similarly, 15 meters will lose propagation to Europe shortly after European sunset, and 20 meters will lose propagation to Europe soon thereafter. On paths to Japan, direct path 40 meter propagation towards the northwest is unlikely except for a very brief period at 0800Z (Japanese sunset) and during the hour so around 1130-1230Z (our sunrise). During the remaining hours, propagation to Japan will be over the familiar (to 40 meter DXers) southwest skew path.

On 15 and 20 meters, evening openings to Japan will be brief, beginning shortly after 2130Z (sunrise in Japan), and failing shortly on 15 meters after our sunset and soon afterwards on 20 meters. The morning 20 meter direct path openings to Japan we've become used to on 20 meters during high sunspot years will be only a distant memory as the mid-latitude trough kills that path during the Japanese night-time hours.

The mid-latitude trough can be very beneficial on long haul 160 meter paths at sunrise on the eastern end of the path. Ionospheric tilts occur in the vicinity of the trough, occasionally producing tremendously enhanced 160 meter propagation at our sunrise on our path to Japan. I've experienced several JA sunrise openings when the JAs are an honest "20 meter

S9". It's amazing to listen to their S3 signals build up to S9 over about a 5 minute period, stay at that strength for 10-15 minutes, then steadily fade away as absorption takes over with the rising sun. On those occasions I've had runs of 20 or more JAs on 160, just as on 10 meters when propagation is good. Fig 1.6 at <http://www.radtelnetwork.com.au/propagation/hfprop.htm> shows an illustration of the MUF at the mid-latitude trough. Although the article says the mid-latitude trough occurs at 60 degrees north and latitude, recall that it's occurs during winter and in the vicinity of the equinoxes, so you would rarely experience a mid-latitude trough simultaneously at both north and south latitudes.

As we approach solar minimum, we should be prepared for shorter openings over the north Atlantic and north Pacific paths. Knowledge of propagation phenomenon will be more of a strategic advantage than during the high sunspot cycle, as openings become more fleeting. Operators who are aware of these patterns will be less likely to be disappointed by missed opportunities.

---

## The Toolbox

By Don Daso, K4ZA

Recently, one of the locals was wandering around my QTH (we were supposedly searching for some aluminum tubing from the K4ZA stockpile), when the subject shifted to the base of my 10 MHz vertical.

"Where'd you get that beautiful ground ring?" he asked.

Naturally, I was surprised and delighted that someone would think that something I'd made would be beautiful, especially considering this antenna was constructed completely from cast-off pieces, parts, and scrap.

But I realized the ground ring might warrant a few comments, considering how several other people have now heard about it, and have also asked me for details.

Basically, the ring, or plate, is one half of what's known (in my industry—film and video production) as a 1-inch (Type C) videotape reel. One-inch videotape typically comes in 34-minute, 66-minute, and 96-minute lengths, spooled on to aluminum reels that simply look like larger versions of old reel-to-reel audio tape. Really, that's a good comparison; the only significant difference is in their hub construction (audio reels typically spin apart, while the video reels are screwed together). Since the advent of Betacam and other cassette-contained videotapes, 1-inch popularity has steadily declined. So much so that many production companies and post-production houses have taken to throwing out their old 1-inch tapes. And while the old oxide-based tape itself isn't real valuable, I've always felt the reels would or could be, and have saved them whenever I could.

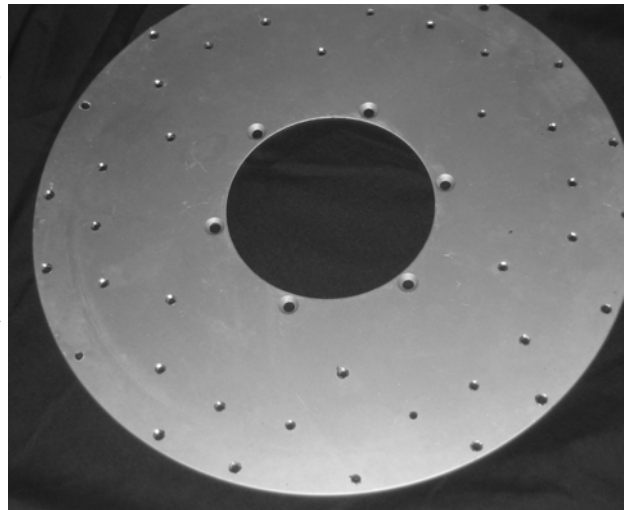

So, one day, while looking at the Lance Johnson Engineering GP-1 ground ring, it occurred to me that I could simply take a 1-inch reel apart, throw away the hub, drill some appropriately-spaced holes around the perimeter of just one of the aluminum reels, and *voila*, I'd have my own no-cost version of this handy item.

The reels are usually made of a hard alloy (not unlike 6061-T6), and are usually from 6 inches to 12 inches in diameter. The hub opening is 3.5 inches. A few minutes with a drawing compass will give you perfectly spaced and aligned hole locations. A few more minutes with a center punch & a sharp drillbit and you have a very neat ground ring base. A photo of one such ring is included (see above). I usually drill holes both on the perimeter edge and then further "inside" the perimeter, allowing me to attach more radials at a later date, or to facilitate different lengths or sizes of wire. I usually use stainless bolts or machine screws to attach the terminals, using Penetrox at each connection.

A few minutes with such reels will provide you with a unique and useful tool. I'm sure you can think of a myriad of uses for these "junk" pieces yourself. (For instance, fastening aluminum angle to the plate with an SO-239 mounted on it for the vertical element, and so on. There's something neat and clean about having the radial attachment as a circle, too!)

I was pleasantly surprised to receive so much attention from last month's column. Along with requests from clubs and groups to reprint the note, along with lots of e-mail traffic (only one was negative, by the way!), and then a note from the

League saying they'd print the tip in "Hints and Kinks," which was a treat. I hope this month's column meets with similar reactions.

What have you made using trashed items; what recycled gems can be found in *your* Toolbox?

## **VHF and Above Radio Frequencies**

**Once thought of as useless, now one of the most sought after resources in the world ... use them or lose them!**

**By Chuck Watts, W4XP**

The East Tennessee DX Association (ETDXA) is sponsoring the 2004 Spring Sprints. The ETDXA is also collecting and compiling scores for the Sprints. As the cliché says, "if all goes according to plan," I should have my newly acquired Rohn 25G tilt-over tower installed in time for this year's Sprints and I plan to be on in all of them, even if it's just for a portion of the contest period, to show support for the ETDXA efforts in keeping the VHF and above Sprints alive.

These Sprints are the perfect time to check out how well your VHF and above antennas survived the winter. And it may be the first time you've fired up that amplifier and you will have to "cook" out, literally, the bugs that found their way into the hardware. I'll have the opportunity to try out my "new" 8874 amplifier on 222 MHz and see if the capacitors in the power supply of my modified DTR-2000 will explode when I fire up for the 50 MHz Sprint!

The rules for all of the band sprints are the same and are available at: [http://www.etdxa.org/2004\\_spring\\_sprint%20rules.htm](http://www.etdxa.org/2004_spring_sprint%20rules.htm). Put the dates for the 2004 Sprints on your calendar! Here are the times for the bands:

The 144 MHz Sprint will be from 7 PM until 11 PM local time on Monday (April 5, 2004).

The 222 MHz Sprint will be from 7 PM until 11 PM local time on Tuesday (April 13, 2004).

The 432 MHz Sprint will be from 7 PM until 11 PM local time on Wednesday (April 21, 2004).

The Microwave Sprint will be on Saturday (May 1, 2004) from 6 AM until 1 PM local time. This includes all Amateur frequencies above 902 MHz. Please include band data in summaries and logs. NOTE: use of Liaison Frequency is encouraged. And the last band,

The 50 MHz Sprint will be from 2300Z Saturday until 0300Z Sunday (May 8 & 9, 2004).

Exchange: Call sign and 2x1 degree grid-square locator. As in most VHF+ contests, signal reports are optional; QSO Points are 1 point per QSO. The total score is QSO points x grid squares. Rovers score same, but please segregate logs by grid. Scoring for Rovers is cumulative, total number of grids worked from each grid activated multiplied by total number of stations worked in each grid activated. Logs due 4 weeks from the end of the contest in ARRL VHF contest format.

After the Sprints comes the ARRL June VHF QSO Party. The "granddaddy" of VHF Contests, not because of the number of participants, but because this is a contest where your score can be affected by more factors than can be thoroughly discussed here. Possibly the most influential factor is E-layer reflection (E skip or Es), or more likely the lack of Es propagation. If there is significant Es it is usually most beneficial for the folks located in the Midwest or extreme Southeast. However, it is not uncommon for significant Es "clouds" to form over the Northeast, too.

Another common summer time propagation is the inversion, especially the coastal form. Stations located along both coasts can see significantly long paths, Maine to Florida, as an example for the East Coast, California to Hawaii or Northern California to the Baja Peninsula for the West Coast. Stations at higher elevations sometimes will not benefit due to the fact that these locations can be above the inversion layer. A quick check of the Aviation weather forecasts for a day or two before and through the contest period will yield some insight into the temperatures aloft. Sites like <http://aviationweather.gov/> will give both surface and upper atmosphere temperatures and winds. Knowledge of both temperatures and winds are important in predicting Es and inversion activity.

Two other propagation modes experienced in the June VHF contest are, rarely, aurora and, almost always to some degree,

tropospheric. There are two great tools to aid operators in assessing the likely hood of either mode occurring. William Hepburn's tropospheric maps for North America and various parts of the world is one. These maps show potential tropospheric openings for various continents of the world. William updates these himself, and attempts to show 3-day forecasts <http://www.iprimus.ca/~hepburnw/tropo.html>. The other tool is useful in predicting the likelihood of aurora. At <http://spaceweather.com/>. A typical Watch report looks like this:

**AURORA WATCH:** Earth will run into a solar wind stream on or about **Feb. 29th**, and that could spark auro-ras. The best displays will be at high latitudes--*e.g.*, Alaska, Canada and Scandinavia.

Spectacular photographs of aurora by visual observers frequently accompany these reports. Check these sites out and see what is available. It should be obvious that some of the information is applicable to HF contesting as well as VHF+ activities.

There is, on several Internet SIG (Special Interest Group) Reflectors, a vigorous discussion in progress debating proposed changes to ARRL sponsored VHF and above contests. At this writing nothing is "solid" as to what changes will be imposed, if any, this year. I'm certain that W3ZZ is an informed source on this subject, and Gene will have something in a future *World Above 50 MHz* column in *QST*. Proposed changes in the VHF+ contests will affect the club competition category as well as individual and multi-operator groups.

The original e-mail that started the discussion is too long to reprint here, but if you're interested send me an e-mail and I'll forward it. I should be able to present a summary of the proposal, and some alternatives presented by the VHF community, in the April column.

If you have suggestions or comments, please contact me at [w4xp@arrl.net](mailto:w4xp@arrl.net) or send me a message via the DXCluster.

---

## TR-LOG -- Dynamite or Dinosaur?

By Jim Jordan, K4QPL

My first thought was to write another one of those "Mine is best" articles. Thinking better of it, this would be unfair to the talented amateurs who invest countless hours fulfilling the essence of amateur radio--innovation and experimentation. Writelog, MM, TR, CT, NA, MTTY, etc., are all great programs which would never have been written by anyone motivated entirely by profit. Likewise, I don't believe there is a "best" logging software for every mode and environment. The well rounded contester should probably have two or three different programs on hand. How many golfers use just one club?

For CW contests, SO1R and especially SO2R, I think TR-Log, written and supported by "Tree", N6TR, has reached a state of refinement, flexibility, and reliability nothing else can match. Old technology--sure. But like a classic car or good red wine, it just gets better with age. And like those, it must be given care and TLC to be fully appreciated.

First, match TR up with the environment it was written for. It's not network-ready and it won't like your new Pentium giga-whatsis with Windows XP. Find a 486 or higher DOS machine from the mid 90's. They can be picked up for next to nothing or "liberated" from your office store room. A late version of DOS is best, maybe 6 or 7. While you're at it, add another parallel port. Pull out unnecessary cards, especially modems, sound and network cards and anything else which will hog the interrupts. All you want are good COM1, COM2, LPT1 and LPT2 ports. Disable those phantom COM3 and COM4 assignments. For two serial interfaced radios and packet, however, you may need a third true COM port. If you have an old Epson printer for your QSL labels, so much the better. Don't forget a PATH statement in your config.sys file for C:\LOG which is where you install the program. Add serial interface cables to match your radios. I recommend wiring up one of the parallel cables with both the CW output plug and a jack for your paddle. Schematic is in the manual. You can build it into the plug or in a separate box. If you don't have room for an extra monitor and keyboard, a KVM switch might be a good idea.

Install, but don't just wait for pretty pictures. With standard defaults, you'll be less than satisfied. Tree does give the option to just step through and start contesting. That can be misleading as you might then think you know this beautiful program. Open the hood, understand the capabilities, read the manual and keep it close by. Update the manual from the README file in each upgrade. Alt-H and Ctrl-J give limited on-screen help and customizing options, but using a text editor to customize your config files is where you find the gold.

TR-Log is like CW itself. It takes skill and practice to do well, but once mastered, is reliable, provides lots of real-time data and lets you concentrate on the contest. For SO2R, TR really is dynamite. When you finally get the nerve to turn TR loose in full interfaced two-radio mode, it is awesome! While one radio is sending CQ; you dupe check on the other radio; If not a dupe, TR holds the call in a small window. When there's a break in your run, hit the key and hang on. Radio 2 drops your call; Radio 1 restarts to hold the run frequency; Radio 2 goes into exchange mode, logs the mult and Radio 1 is running again in half the time I can describe it. No tricky key strokes and no snafu's. With TR as your keyer, the paddle halts the program and lets you greet a friend, react to the unexpected and simplify fills. Great in a pileup to kill the QSL and catch a tailender.

In addition to rock solid reliability, flexibility and customization are major strong points. Every TR user sets up differently. To save time, you can type all your station parameters into one subfile (ports and commands for interface, paddle, cw output, band output, PTT etc.) as well as any of the huge variety of available preferences. That file gets "called" by the specific contest file. For example, with the text editor type "INPUT CONFIG FILE = C:\LOG\K4QPLCW2.CFG". Create folders for each contest. Use a system like C:\LOG\CONTESTS\ARRLDX and then when you set up ARRL DX, name the contest file something like 04FEBCW.CFG. Insert your contest-specific variables in that file after calling your station parm file. Next year, just do a "COPY 04FEBCW.CFG 05FEBCW.CFG" command and you're ready to roll with no new setup at all. Your data files will also be given the new name. Chances are that upgrades will not upset existing commands. The TR Contest library is huge. Post contest routines include Cabrillo conversion.

The variety of customization is endless. For example, I don't number my radios. They're port and starboard, red and green. I color code and name TR screens for each radio along with red and green LED's for audio and on-air indicators and colored tape for cabling. Surprisingly useful at 3:30 a.m. Bandmapping for S&P is brilliant with choices for one band, all bands, radios, guard bandwidth, colors, decay rate, etc. Jump your cursor to the band map to check back on a pileup when you don't want to wait. There's also a Visible Dupe Sheet in colored columns by call areas which is particularly good for Sprint where normal bandmapping is useless. Speaking of Sprint, TR is totally intuitive, alternates modes and warns if you fail to QSY.

Another cool feature is using the left and right shift keys to tune the VFO in S&P and slew the RIT when running. (RIT slew not available for all radios.) A character insert in your exchange recenters the RIT after each QSO. I've done a Sprint and almost never touched the radio at all. Enter a specific frequency in the call window and you're there. Great for NAQP QSYs. You can also vary the CW speed of the components, like your call, within the exchange message itself.

I could go on forever. Bottom line, if there's a parameter you want to change, you probably can. Keyer attributes and keyboard sending, of course. Delay and hang times to assert PTT to the linear, sure. QTC's, SCP, data base calls, customized F-keys, absolutely. Or create an Alt Function set for the second radio. After editing the program, delete the restart file with the DOS command DEL \*.RST@ so your changes will take effect when you restart.

Speaking of restart, TR is superbly fail-safe. Critical data is backed up after every QSO. Power blink, or the cat yanks the line cord, no problem. You can also backup to floppy every nn QSOs just in case Murphy attacks your hard drive during the contest.

If you're strictly a Plug and Play type, go with Writelog and accept the compromises that are inherent with simplicity. But if you like to learn and to optimize your interface controls and logging, you'll have fun with TR, you'll up your rate and lower fatigue. Print out the manual, it's definitely worth the paper and ink. Buy the annual support and upgrades. Reasonable and you'll see just how great the support is. Several upgrades will be e-mailed to you each year. More help is on the TR list-serv. Customizing TR is a great way to spend a winter's evening preparing for a contest. Besides, it's a heck of a lot warmer than climbing towers or slinging wires!

Questions or need help? E-mail me -- [K4QPL@nc.rr.com](mailto:K4QPL@nc.rr.com)

---

**Don't miss this year's remaining 5M Contests --  
ARRL DX Phone March 6-7... Russian DX March 20-21... WPX Phone March  
27-28... WPX CW May 29-30... ARRL June VHF QSO Party June 12-14**

**GO PVRC!!!**

## Beverage Antenna Controller

By Mike Sims, K4GMH

For those of us with radios that don't provide a receiver only antenna input, the schematic shows my way solving this problem. In addition, the circuit keeps me from transmitting into one of the Beverage antennas. Also, Beverage antenna selection was incorporated. With the constructed circuit, the receiving Beverage antennas at K4GMH are selected and automatically switched in during receive without the possibility of transmitting into one of them.

The relays used are P&B RTE24012F. They are "overkill" for this application as these are the same type used in my various remote antenna switching projects. The relays will pass 1500 Watts to a nominal 50 Ohm load when wired as a SPDT and cost less than \$3.00 each. The diodes are 1N4001. The switch is a DP3T, but should be selected for your application. In my case, the switching arrangement is used to select West or Northeast Beverage antennas. One set of contacts on RLY1 is used to key my amplifier. This latter feature isn't part of the automatic receive antenna selection, but the set of contacts on RLY1 were available.

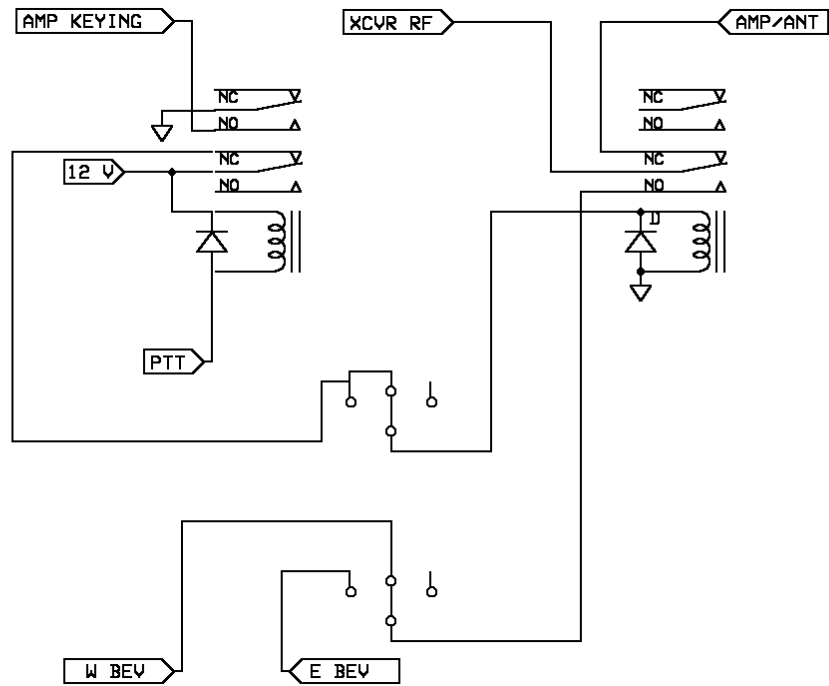

## This Just In ... YI3DX (W3ICM) Dishes Out the RF in Baghdad



As you can see, Fred's shack arrangements have a certain temporary feeling to them, but he's there for the deserving. Better get him before June 30!!

## **Club Victory in WPX By Bob Dannals, W2GG**

WPX CW scores are out. Congrats to everyone for a club victory. We were #2 US to NCCC but since NCCC won world, we were awarded #1 US.

Also, congrats on World #1 finish to M/M NY4A (N4AF and team) and #1 USA M/2 to KM4M (K4JA and team).

Plus USA SO Assisted #1 to WM4RM (W4RM), #5 K3KO, #9 K3WA, and #15 W3HVQ.

USA SOAB LP #3 to NY3A, #9 WJ9B, and #15 N4YDU.

USA SOAB HP #6 to W4MYA, #12 K3ZO, and #14 WR3Z.

USA #1 Tribander/Single Element to K2PLF and #7 N3UM.

USA Rookie #1 to AI3M.

USA #1 21 MHz to KD4D and USA #10 14 MHz to N8II.

And #1 QRP 14 MHz to WA8WV.

---

### **Around the Club Meeting minutes from the regions**

#### **PVRC/CVCC Jan. 13, 2004**

The regular monthly meeting of the CVCC at Henrico Doctors' Hospital, Parham Road Campus, was called to order at 7:03 PM by president Roy Davis, Wk4Y. Eighteen members and guests were present. Members and guests introduced themselves. Bob, W4MYA, announced that there would be no more multi-station contests from his place. Bob, W4MYA, presented the program for the evening - a video of the July 2002 World Radiosport Team Championship (WRTC) contest held in Finland. Participants drew envelopes at random to determine their QTH, host and referee for the contest. All teams have identical antenna systems, but other equipment is up to the team. About 80% used Yaesu 1000MP or 1000D transceivers. Referees called in scores every hour via text messaging. There was concern if realtime scores and posting on the internet could bias competition.

Items of business:

FrostFest will be February 22. Order VIP tickets online. Volunteers are also needed and appreciated. Ed Moore, NW4V, is chair for nominations for club officers. Nominations will be made in March and voting will be done in April. Tom, N4ZJ, can no longer edit the newsletter. Send band entity update to John, w4tnx@comcast.net. List numbers by band - 160 - 6M, indicating 0 if none for a band. Packet cluster news - new AR callsign database was installed. Show/ham gives QSL information. Show/wx zipcode gives live weather for area. A motion was made by Dennis, N4DEN, to donate \$100 to QSL.NET. AC, W4HJ seconded the motion, and the motion carried. Ralph, N4EHJ, suggested that we hold a contest club net and suggested using the 146.58 or asking MRA for a night.

Marie Long, K4KML, Secretary

#### **Laurel Chapter, January 28, 2004**

The following members were in attendance: KB3BWR Toby Widdicomb, WI3N Jim Cross, KT3D Dennis Fitzgerald, N3TZA Joe Craven, KA8YPY Dan Blasberg, WV3D Kevin Craven, and N3XL Bill Smith. Ed Herbrechtsmeier, KB3KQX visited and expressed interest contesting. He is setting up his shack now.

The useful and entertaining ARRL Contest Rate Sheet by Ward Silver, N0AX, which is published weekly via e-mail, and free for ARRL members, was pointed out to the membership. Using contests and QSO parties as a method for obtaining rapid fire contacts for awards, as well as for PVRC points, was discussed. CW contesting and training techniques were



discussed. Bill pointed out that by creating a file of callsigns you can use G4FON's Koch Method Trainer as a way to practice simulated runs. The spacing used between the callsigns will determine how fast the next call is sounded. This way you can give yourself a little time to make the log entries between calls, just as you would in a contest.

Bill Smith, N3XL

### **Southern Maryland, February 5, 2004**

In attendance were the following members: Barry WR3Z, Wayne N1WR, Mark KD4D, Tom K3DSP, and Marty W3YOZ. Guests included Gene Talley N3NO + XYL Suzanne N3JTR, Dave Craig N3DB + XYL Lisa and newborn Matthew.

A break in the poor WX of late was the perfect time for a dinner/meeting over on Solomons Island. With the emphasis of the dinner being a social gathering, recent/planned radio activities were discussed (especially VHF/UHF). Also, pictures from Barry and Rob ND3A's vacation in Australia were passed around to the group.

Barry WR3Z operated both CQWW contests as part of the M2 set-up at N4RV with considerable success. Barry also participated in the January VHF contest with the W3SO LM group in FN00 as one of the 6M ops, and plans to be back at N4RV for both ARRL DX contests.

Wayne N1WR has had limited activity of late due to antenna problems resulting from Hurricane Isabel. Repairs have not taken place of yet due to a combination of the poor WX as well as recovery time from surgery. Wayne expects to work on the repairs once the WX improves.

Mark KD4D operated at W3LPL for both CQWW contests as well as the 10M Contest. Along with his operating at W3LPL for the ARRL DX contests, Mark plans to operate as part of the K4JA team in WPX SSB and has looked in to operating up in VY2 for the WAE CW contest.

Tom K3DSP has been the most active of the local members, with scores submitted for CQWW SSB, ARRL 10M, ARRL 160M, and January VHF contests. Tom plans to operate in the upcoming major contests as time permits. Great job Tom!

Marty W3YOZ made the trip down for several reasons, the two most significant ones being (1) a love of seafood, and (2) continuing his quest to be able to attend at least 1 PVRC meeting in every region. The trips most every weekend up to Altoona culminated with a pretty successful showing for W3SO in the January VHF Contest, with a LM score of 217K. This was despite an additional 6" of snow on top of +12" already on the ground. But Marty has been able to put together a group of operators, both local to Altoona and from afar (DC area, northern MD, and MD Eastern Shore), to now have a very competitive LM station. Marty does plan to take a little time off to continue his cleanup from Hurricane Isabel, but will otherwise maintain the W3SO station along with W3TEF, KD3SA and W3BTX to prepare for the June VHF contest.

Both Gene N3NO and Dave N3DB have expressed interest in joining PVRC. N3DB, as many of you may already know, has become a very active 6M operator and has a wealth of knowledge of VHF/UHF operating and propagation techniques. Dave's call sign is seen quite often in the VHF column of QST, and has operated both SO and LM in the recent VHF contests. N3NO, who by the way is N3DB's father-in-law, just recently retired for the Patuxent River NAS (where WR3Z works) and, as an admitted casual operator, has quite an impressive station for his love of chasing DX.

See you in the pileups,  
Barry, WR3Z

### **PVRC/NC East, February 5, 2004**

Members Present: Guy K2AV, Jim K4QPL, Wes K4WES, Bob N2NFG, Tom N4TL, Jeff NX9T, Gary W2CS, Jim WW4M. Regrets: AD4L, AE4EC, K4HA and N4CW

#### **Chapter Business**

Guy opened the meeting at 6:40 and announced that the East/West Carolina get-together will take place Wednesday evening March 10 in Burlington (mid-way between the Triad and Triangle). This will be the March meeting for the NC-East group (no meeting on the 1st Thursday in March). In the future we'll hold these meetings biannually on the equinox (Guy must have some Methodist/ pagan thing going on). Details as the date approaches. I'm sure some of us will be interested in

carpooling. Contests coming up: CW Sprint, ARRL DX/CW, CQ 160 SSB, NC QSO Party

Member News -- Ed AE4EC reported by email that he'd operated in "WAE both ssb and cw, ARRL SS both cw and ssb, ARRL 10M, CQ WW both cw and ssb and cq 160M cw. I plan to operate in the ARRL DX, CW and the CQ 160M SSB test this month especially if I can get a new inverted L up in time for the 160M test. Definitely hope to meet with the club in March." Guy K2AV has picked up an Alpha 76 PA from Ron N4XD & thinks it's a dandy rig. N4XD has replaced it with an AL 1200 so he can run power on 12m. Jeff NX9T had shoulder surgery since our last meeting (he's doing well) but still managed to operate NAQP, ARRL VHF SS, and CQ 160 CW. He is looking forward to the SSB Sprint this weekend and the upcoming CQ160 phone test as well as the others later next month. Jim WW4M helped Jeff N3NPQ put up his rocket launcher tower for the VHF January Sweeps. Jeff's now QRV on 6m, 2m, 220, 432, and 1296. Now if only there were someone to talk to on 1296 in Chapel Hill.... Jim K4QPL operated in NAQP and the 160 CW test and thought the conditions during the 160 contest were great. He's getting close to finishing his new garage / shack: the insulation is done and the drywall can go up when he inspection is completed. Tom N4TL made a contact in in the CQ 160 contest and brought his homebrew 160m preamp for show and tell. Bob N2NFG has not been active recently. He missed SS due to a broken leg and then Writelog bit him on the @#\*\$\* during NAQP (the RTTY window kept popping up). Good news: he moved into the new house which has a room dedicated to radio. Bad news: the landscapers landscaped right over his guy anchors, so now he'll need to replace them and since he can't relocate them he'll need to use concrete. Wes K4WES operated in the NAQP. Gary W2CS also made 1 contact in the 160 contest -- he worked N4AF using an 80m antenna. He also operated in the Sprint.

Jim, WW4M

### **Central Region, February 9, 2004**

The meeting was held Monday 2/9/04 at Anita's in Vienna, Virginia. (Having the Virginia meetings at Anita's is new, most of the attendees at the Virginia Central meetings were in favor of doing this. However, Anita's does like to have at least 20 diners to utilize the upstairs room, so it is unclear if the April meeting will be at Anita's or at the library. We will try to get that worked out ASAP and let everyone know.)

The following were in attendance: Pete-N4ZR, Brian-N3OC, Jack-K4VV and guest Danny Jamison-AH6FX, Mark-KD4D, Bob-KC3VO, John-N3HBX, Paul-K4JA, Rich-KE3Q, Marty-W3YOZ, Jim-W4EE, Bob-KI3O, Steve-KB3KAQ, Eric-WD3Q, Jim-N3JT with guest Mark Clark-W4CK, Ron-N4MO, Bill-N3RR, John-N3AM, Marty-K2PLF, Ken-W8JVP, Ray-KT4W, Masa-AJ3M, and Dave-WR3L.

N4ZR presented a Powerpoint demonstration of the N1MM Logger program that is available for free download. Pete's briefing is now available on the PVRC web site for download or (html) viewing at <http://www.pvrc.org>. Thanks to Pete N4ZR for coming all the way from WV to bring us the presentation, to Jack K4VV for making the arrangements at Anita's, to Bob KC3VO for bringing his PA system, screen, and projector, and to John N3HBX for bringing a backup projector.

After the presentation, there were brief comments. Jack Hammett K4VV said that Pete Smith, N4ZR has volunteered to pull together ideas and approaches for needed revisions to the PVRC Bylaws including a revision to the decision-making process (given the nature of our regional club structure), membership requirements (two meeting requirement, once a PVRCer, always a PVRCer, etc.), and various types of meetings. Send your ideas to him.

Rich Boyd, KE3Q, brought up the idea of splitting the Central Region into two parts, with separate meetings in Maryland and Virginia. We will look into this further. The next Central region meeting will be in Temple Hills, MD on Monday, March 8, 2004. Dinner beforehand at Topolino's around 6pm for those interested. It is anticipated the program will be a presentation from the ARRL on ham radio public service activities that PVRCers could participate in, although the presentation is not confirmed yet.

73, Brian N3OC

### **Carroll County, Impromptu PVRC Work Session, February 14, 2004 WX3B**

In attendance: N3SB, NY3A, WX3B

It was a chilly evening when N3SB knocked on WX3B's door at precisely 9:00pm as planned. Steve entered the house

with magnifying glasses, special glasses you wear, and other super small devices including some 50 ohm resistors. We had a mission: Repair the 6db attenuator on the new (used) 160 meter Kenwood TS-850SAT and perform two other upgrades at the same time.

Steve, NY3A brought over a Delorme product which had maps with extreme detail of our surrounding topography. We spent a great deal of time looking at the elevation surrounding both NY3A and WX3B. Steve (NY3A) decided he needs about another 50 feet of tower to get rid of this hill he has 3 miles away, attenuating JAs by 10db or so.

Meanwhile, N3SB pulled apart the 850 and removed one of the boards, turned it upside down, and exposed dozens of surface mounted devices. With a large magnifying glass, it became obvious that a resistor in question had been burned up (as suspected). We measured the resistance and it was open. Steve meticulously replaced the component and Jim is still in awe that anybody can work on something that small; it's a well known fact that Jim doesn't even like soldering up microphone cables!

Next, Steve added the CW sidetone volume control for the 850. This is a relatively simple enhancement that brings the sidetone volume control up to the front panel monitor control. Last but not least, Steve defeated the 850's famous broadcast band (40 meters) attenuation circuit. The night was considered a wild success and Pizza was served as the reward.

A hearty thank you goes out to N3SB for trading several hours of surface mounted hardware engineering for several slices of Pizza!

#### **Carroll County, January 31 & February 7th, 2004**

In attendance: N8II, K3ZE, N3KS, K3LP, W3ARS, N3FX, W3DF, WX3B

Round II of the FS5UQ DX-Pedition preparations began at 9:00pm at WX3B. This time the weather cooperated, and everyone was able to participate. Jeff, N8II gets the award for the die-hard of the group; he traveled over 2 hours from West Virginia to meet everyone. Jeff is very excited about the upcoming trip to St. Martin.

Al, K3ZE was the drink supplier of the evening (Soda - that is) and he enjoyed socializing with the group and hearing about the big plans. Al's announcement was that he had fallen in love....with the Icom 746! We're waiting to hear how that romance progresses.

This was the first time I had the pleasure of meeting Kam, N3KS, though many of my friends have met him years ago. This will be Kam's first major contest DX-Pedition/Vacation.

David, K3LP was helping Jim dust off his two Yaesu FT-1000MPs that had been involved in a massive construction project....a.k.a. the building of David's house. Once we established that the radios were configured identically, and neither had the 2.0khz SSB filters in them - the tests progressed and we pronounced both MP's ready for the contest - everything worked!

Clint (a.k.a. "Bubba") W3ARS was so excited from his last trip to FS5 that he could hardly contain himself. He was the center of attention in the "let's get the computers networked" department. Well we ended up working for several hours trying to connect to the network...and it didn't happen. Fortunately, Clint figured it out later on in the week.

Tony, N3FX was assisting in the "media conversion" project trying to get network drivers zipped up and on the net for Clint. Even though Tony is not part of the FS5UQ DX-Pedition, we put him to work just like he was.

Dan, W3DF had another reason for visiting WX3B. Dan collected sample plans for WX3B's review for potential home building. Dan commented that the WX3B basement looked a bit different than it did at his last meeting. Dan also denied that he is interested in being WX3B's QSL Manager.

In addition to testing out David's two Yaesu FT-1000MP's, we did some preliminary testing of the writelog network and David ordered a copy of the software for the upcoming trip. CW keying interfaces were also tested. At the end of the evening we admitted that another get-together was necessary to iron out all network related issues.

Adventures in FS5UQ Preparedness Continued: February 7th at K3LP

In attendance: W3ARS, N3KS, WX3B, N3VOP, K3LP, Rebecca and Ryan

The story continued at K3LP's house the following Saturday. This time the goal was to build some wire antennas, and to get the contest logging program writelog networked, tested, CW interfaces tested, etc. Murphy reared his head again, this time on Clint's notebook PC - when the parallel port was not recognizable. I've never seen this error before! The solution to this problem was to buy a USB to RS-232 interface and use a serial CW keying interface for that notebook. Clint and Kam worked through that themselves after this get-together.

The other interesting problem took 2 people 2 hours before we gave up: we couldn't get Kam's Windows ME PC to network with the others. We gave up at about 2:00am and called it a night. Kam determined later that the Windows registry was at fault - and after a format to the C: drive and a re-load of Windows ME - the system came right up and networked like a charm.

Mike, N3VOP won the "good sport" award of the evening since he patiently waited for Clint to stop fussing with PCs before car-pooling home with him.

Thanks to David's Wife Rebecca for the great food (Meat-Ball Sandwiches & Drinks) and of course my personal highlight of the evening was holding Baby Ryan Colingham, only about 2.5 months old! Now if we can just get him to yell "K 3 LIMA PAPA.....LIMA PAPA.....LIMA PAPA!"

These adventures underscore the importance of good planning - before you get to your exotic destination. Any one of these issues might have been unfixable in a remote location.

Submitted by Jim Nitzberg, WX3B

#### **Northwest Region, February 17, 2004**

The NW Region met at the City Buffet in Frederick, MD. In attendance were W6NRJ, K3WC, K3TZV, N4MM, K8OQL, W2YE, K2PLF, W3KHZ, N3VOP, W0YR, K4VV, N3HBX, K3ZO, W3ZZ, W8ZA, WD3A and W3LL.

Announcements:

W3LL, Bud: Look for, work and spot our PVRC team in the ARRL DX CW Contest at FS5UQ - K3LP Dave, W3ARS Clint, N8II Jeff, N7DD Larry. Echolink Internet roundtable discussing ARRL CW & SSB contests will again be hosted by Pete, N4ZR at 8:30PM on 19 Feb. Connect thru WM3T. Newsletter Articles are needed for upcoming months. Submit to Pete, N4ZR - n4zr@contesting.com.

N3VOP, Mike: Clint, W3ARS will be trying 6M EME on 50.190 Mhz at FS5UQ using WSJT (JT65B), a 5-7? el Yagi, 847 Xvr + Amp. N4MM, John: Manassas hamfest will be held on 06 June. SE VHF Society will sponsor an award for working all EM grids. ARRL eliminated 3 awards for lack of interest: Friendship, Old Timers and Ragchewers Club.

W3ZZ, Gene: Look for VHF Contest changes coming in 2005.

K4VV, Jack: The Trustees and Officers had a lively Internet discussion about lagging PVRC competitiveness, based on some decline in log submissions. Jack said that he and the Regional Chairmen have the responsibility to address the issue. Comparisons were made to the early days where a champion made personal contact with every member to convey interest by the club in their individual participation. One example was SMC's effective president who is very involved in recruiting and contest participation. Our regions may be effective in providing social structure but may not have the "fire in the belly" for promoting contest participation. W2YE, Dick attributes this to our strong local club affiliations. Local clubs are also submitting scores with pressure on members to contribute to local clubs rather than PVRC. Local clubs look for notoriety through published results. N3VOP, Mike noted that the Carroll County ARC uses their club call for score submittal with affiliation to PVRC.

W3ZZ, Gene commented that PVRC needs to decide where we want to compete. SS is an example where most have the capability to compete. He suggested a callup list of inactive members soliciting/pledging contest points. K4VV, Jack described the very diverse interests of the club members as a counterpoint to focusing on narrow interest sectors. W6NRJ, Jim suggested station owners encourage their use by inviting those who can't setup a station. Multi-single has

more potential for point generation than separate single stations. K3WC, Dusty suggested we encourage K3EAR to join PVRC. K4VV, Jack said that he had contacted the leader of the K3EAR station, with no interest found. He reiterated that the club regional leaders are not mobilizing the members to be competitive. K3ZO, Fred commented that there are those who say "if you think you can do a better job then go ahead". There hasn't been competition in the elections in a long time. W6NRJ, Jim suggested obtaining area cluster membership lists for soliciting invitations to operate at local stations.

N3VOP, Mike hasn't seen PVRC put on "how to" demonstrations other than the N1MM demo. K2PLF, Marty suggested that as a club we should focus on three or four contests with an all out effort rather than spread our resources. W0YR, Mike noted that perhaps new members aren't given the club's expectations of them. The executive committee or steering committee should come out with a statement of expectations - like a preamble or credo or company mission statement. K4VV, Jack stated that the by laws are being reviewed, including membership requirements, dues, various types of meetings, and voting. K3ZO Fred said dues are a bad idea. W8ZA, Bob says participation at his multi-multi station is laid back but it's still difficult to get operators. Some may be afraid they are going to look bad.

W3ZZ, Gene went into a great nostalgic contesting story ending with a lament that there are no more young hams. W0YR, K4VV, K3ZO and W3ZZ followed up with not to be missed stories of the past. K4VV, Jack noted that the NW meeting in Frederick has become the most well attended meeting in PVRC. However, the Central meeting last week outdrew NW attendance with Pete, N4ZR's N1MM logger presentation.

The meeting was adjourned at 8:30PM with a good time had by all. The next NW Region meeting is Tuesday, 16 March.

73, Bud Governale, W3LL

The **Over the Hill Bunch** met at the College Park Holiday Inn at noon on February 18 for lunch. Those attending were Frank W3LPL, Tony K3WX, John N3AM, Bill W3AZ, Gene W3ZZ, John W3BE, Robert W2BZR, Lawrence W3GN, Fred K3ZO, and Larry WA3KOU. There were many simultaneous QSO's on various topics. A good place to get in training for the coming SSB CQ DX contest.

# *C3i*<sup>®</sup>

**Finest Quality, Superior Performance, Lowest Cost**  
**Call, FAX, E-mail or Order from our Web Site**

**Our VHF and UHF Yagis are proven performers in Contest**  
**after Contest @ K8GP / FM08fq**

**50 MHz through 1296 MHz**

**GO WITH THE WINNERS**

VISIT OUR HOME PAGE TODAY FOR MORE DETAILED INFORMATION

<http://www.c3iusa.com>

1-866-229-2377, PIN: 4455

Warrenton, Virginia



**PVRC REFERENCE PAGE Please send corrections to the editor. March 2004**

**PVRC OFFICERS:**

President K4VV Jack Hammett 540-882-3188 k4vv@aol.com  
 VP-North N3OC Brian McGinness 301-924-1712 n3oc@wirelessinc.com  
 VP-South K2AV Guy Olinger 919-362-9461 k2av@contesting.com  
 Secretary W2GG Bob Dannals 410-472-2004 rfd@jhu.edu  
 Treasurer WR3L Dave Baugher 410-DX1-WR3L dave@wr3l.net  
 Trustees: K3MM KE3Q N3RR N4ZR W4MYA W4ZYT N4AF K4IQ ND3A W3PP N1KC  
**PVRC Charter Members (\* =SK) W3GRF\*, W4AAV\*, W4KFC\*, N0FFZ\*, W4LUE\*, W7YS, VP2VI/W0DX\*, W3IKN, W4KFT**

**PVRC Reflector** administered by N4AF <<http://mailman.qth.net/mailman/listinfo/pvrc>>, postings to <pvrc@mailman.qth.net> (Members only, if your call sign is not part of your email address, send an email to n4af@qsl.net to subscribe.)

**PVRC Dues** PVRC has no annual dues. Donations are gratefully accepted by the Treasurer, Dave Baugher WR3L, 615 Rockaway Beach Ave., Baltimore MD 21221. Please make your checks payable to PVRC.

**Autocall Column Editor** is K3DI 410-757-6706

**PVDXSN Packet Network**

W3LPL	Glenwood MD	145.590, 441.250	w3lpl.net	W3IP	Crownsville MD	145.570	
WR3L	Baltimore MD	145.610, 440.950	wr3l.net	N3RR	Rockville MD	145.510, 441.325	
K3SKE	Frederick MD	144.930, 441.125		W3YOZ	West River MD	144.910	
W3TOM	Acokeek MD	145.770		N1WR	Lusby MD	145.690	
N4OHE	Mt. Weather VA	145.710, 446.025		NE3H*	Harrisburg PA	144.970	
W3BD	S. Mountain PA	145.630		N4SR*	Woodbridge VA	145.630	
W4XP	Bull Run Mtn. VA	144.990		K4JA*	Callao VA		k4ja.c.crosslink.net
				W4ML	Goochland, VA	145.09	dxc.w4ml.net

Most of the system is sponsored by the Potomac Valley DX Spotting Network. Nodes with \* are independently funded by each SYSOP,. The W4ML node is funded by CVCC.

**PVRC Meetings**

**CENTRAL:** The Central Meeting is always the second Monday (except June, July, and August) at 7:30 pm. The central meeting generally alternates between MD and VA locations. A pre-meeting dinner is usually held between 5:00 and 6:30 pm. Check via 147.000- repeater. VA LOCATION: The Patrick Henry (Public) Library, Route 123, Vienna, VA. MD LOCATION: Church of the Nativity (Episcopal), Route 5, Temple Hills, MD.

Pre-MD meeting dinner at Topoleno's Restaurant about 6:00 or 6:30 pm.

**NORTHWEST:** Chair: Bud Governale, W3LL, 410-666-9189. W3LL@arrl.net. Meets monthly the 3rd Tuesday. Informal dinner about 6pm; meeting at 7pm at the City Buffet, 1306 W Partick St, Frederick, MD 301-360-9666. Rear of shopping center, behind Mountain View Diner.

**NORTH CAROLINA -- EAST:** Chair: Guy Olinger, K2AV, k2av@contesting.com; Sec: Jim Price WW4M. POC's are K2AV and WW4M (h:919-362-4635, w:919-460-2991). PVRC/NC meets at 6 pm the first Thurs of each month, plus an additional meeting in April at the Raleigh Hamfest. For details see <http://pvrcnc.org>

**NORTH CAROLINA -- WEST (TRIAD):** Meets the 4th Monday of the month at 7:00 PM at Cobalt's Elemental Eats and Drinks on Deacon Blvd. in Winston Salem. Ragchew at 6:30. Directions are available upon request. The chairman for the new PVRC/NC West chapter is Henry Heidtmann W2DZO, henry@summitschool.com and the secretary is Robert Whitaker KG4NEP, kg4nep@yahoo.com.

**TIDEWATER COLONY OF PVRC:** This group now meets in conjunction with the Virginia DX Century Club at Ryan's Steak House, which is on Battlefield Blvd in Chesapeake, at the Battlefield Blvd South (VA 168) exit off I-64. The meeting is still the third Tuesday of every month. We gather for dinner around 1815-1830, with the meeting around 1915-1930. Contact W4ZYT at 757-457- 5181 or w4zyt@exis.net for additional info.

**SOUTHWEST VA:** Coordinator: David Jones, N4JED, Vinton, VA 540-890-2034, N4JED@AOL.COM. Meetings begin at 6 pm at the Roanoker Restaurant, Roanoke, Virginia in a private room (ask at the desk if you have not joined us before).

**BWI:** Weekly breakfast Wed at 7:00 AM at Basil's Deli Port on Elkrdige Landing Rd 1/4 mile South of Winterson Road 410-850-4333. Director: Ike Lawton, W3IKE, 410-263-2830. Sec: Howard Leake, W6AXX, 410-465-7008, w6axx1@starpower.net

**OVER-THE-HILL LUNCH BUNCH (VA DC MD):** Meetings are held monthly at three locations: Falls Church VA (Parkview Marriot), Oxon Hill MD, and Beltsville MD. Meetings are announced by E-mail or by telephone. All members and non-members interested in membership are welcome. For information contact Ben Shaver, AA4XU, 703-534-4740 or Bill Leavitt, W3AZ, 301-292-5797.

**PENNSYLVANIA:** Steve Cutshall, K3TZV, k3tzv@paonline.com, 717-763-0462.

**RAPPAHANNOCK:** Steve Bookout, NR4M (ex-NJ4F) NJ4F@erols.com. Also, Larry Schimelpfenig, K7SV, k7sv@va.prestige.net

**OCOQUAN:** Jack O'Mara W4NF, H:703-791-3302 W:703-739-7636 w4nf@comcast.net and Cliff Deel W4CE, w4ce@aol.com 703-491-0841

**CENTRAL VA:** Pres: Roy Davis, WK4Y rdd2@verizon.net (804-741-9315). Sec: K4KML Treas: W4NM Meetings are held on the second Tuesday of the month at 7:00 PM at the Henrico Doctor's Hospital, 7700 Paraham Rd., Richmond, VA. To the right of the main entrance is a second entrance. Go through that door, turn left through that door and the cafeteria is the first room on the right. There will be some who meet at Nick's Roman Terrace, Westlands Shop-

ping Center, West Broad Street starting at 5:50 PM for dinner before the meeting. Talk-in available on 145.430  
**SOUTHERN MD:** Chair: Barry Shapiro, WR3Z. H:301-862-2466 barry.shapiro@navy.mil Meetings held at the home of N1WR.  
**EASTERN-SHORE (DEL-MAR-VA):** Dallas Carter, W3PP 302-875-0550 ludal@dmv.com  
**SHENANDOAH:** Bill Hinkle KV3R kb3aug@juno.com 304-567-3138  
**CARROLL COUNTY:** Jim Nitzberg, WX3B.410-374-9233 nitz@selectsa.com  
**LAUREL:** Pud Reaver W3YD preaver@earthlink.net Laurel Region meets concurrently with the Laurel Amateur Radio club at the first LARC meeting of each quarter.  
**NORTHEAST:** WR3L Dave Baugher 410-DX1-WR3L dave@wr3l.net  
**ANNAPOLIS:** Dick Wilder, K3DI 410-757-6706

**Your advertisement could be appearing in this space.**

**PVRC represents a highly-select group of hams who invest significantly in their stations every year.**

**This Newsletter goes every month to over 600 of them.**

**Contact WR3L or N4ZR for details.**

**PVRC QSLs by LZ1JZ QSL-PRINT**

**<http://www.qsl.net/lz1jz>**

**E-mail:LZ1JZ@MAIL.COM**



**THE R. F. CONNECTION**  
"Specialists in RF  
Connectors and Coax"

213 North Frederick Avenue  
Suite 11-F  
Gaithersburg, MD 20877

**Tech Support:**  
**301-840-5477**

**24-hour Fax:**  
**301-869-3680**

**Order line:**  
**800-783 -2666**

**Email: [rfc@therfc.com](mailto:rfc@therfc.com)**

**Please visit us at:**  
**[Http://www.therfc.com](http://www.therfc.com)**

**Our catalog includes:**

**UHF Series, N Series, BNC Series, Adapters, F Series, DIN Plugs, Portable Radio Power, DIN Plugs, Hardline Connectors, Audio Connectors, Microphone Connectors, FME Series, SMA Series, Reverse Thread SMA Connectors, MCX Series, MMCX Series, Adapter Kits, Reverse Polarity (TNC, N, SMA), 39 coax types and 5 balanced lines**

12 STORE BUYING POWER



# HAM RADIO OUTLET

WORLDWIDE DISTRIBUTION

## KANTRONICS



### KAM '98

- Single port VHF or HF
- RTTY, CW, Packet, GTOR, AMTOR, WEFAX
- GPS, NMEA-0183 compatible
- 6-16 VDC, DB-9 connector port

Call Now For Your Low Price!



### KAM XL

- DSP modem offers great performance on Packet 300/1200, G-tor, Pactor, AmTOR, PSK-31
- RTTY, Navtex, ASCII, Wefax, CW, GPS NMEA-0183 and more!

Call Now For Special Pricing!



### KPC-3 Plus/KPC-9612 Plus

High-performance, low power TNC. Great for packet, and APRS compatible.

Call For Special Low Price!

## GEOCHRON

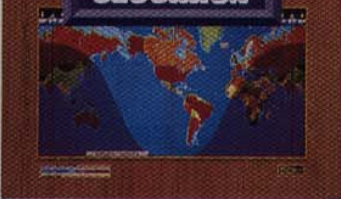

Detailed illuminated map shows time, time zone, sun position and day of the week at a glance for any place in the world. Continuously moving - areas of day and night change as you watch.

• Mounts easily on wall. Size: 34 1/2" x 22 1/2".

Reg \$1295. SALE \$999.95

## ICOM



### IC-R8500 Wide Band Receiver

- 100 kHz - 2.0 GHz\*
- Commercial Grade • All Mode
- IF Shift • Noise Blanker
- Audio Peak Filter (APF)
- Selectable AGC Time Constant
- Digital Direct Synthesis (DDS)
- 1000 Alphanumeric Memories
- PC Controllable w/Optional Equipment

\$50. off street

Call For ICOM Receiver Specials



### IC-R75 Wide Band Receiver

- 100 kHz - 60 MHz\*
- Commercial Grade • All Mode
- Synchronous AM Detection (S-AM)
- Optional DSP w/Auto Notch Filter
- Triple Conversion
- Twin Passband Tuning (PBT)
- 1000 Alphanumeric Memories
- Up to Two Optional Filters
- PC Controllable w/Opt. Equipment

\$50. off street

FREE IC-UT106 DSP thru 3/31

### IC-R3 Wide Band Receiver

- 500 kHz - 2.45 GHz\*
- 450 Alphanumeric Memories
- CTCSS w/Tone Scan
- 4 Level Attenuator
- Telescoping Antenna w/BNC Connector
- Lithium Ion Battery
- 2" Color TFT Display
- Audio/Video Output
- Four Way Action Joystick
- PC Programmable w/Optional Cable & Software

\$10. off street

\*816-901.995 MHz blocked; unblocked versions available to FCC approved users. FM video range for the IC-R3 is 900-1300 MHz & 2250-2450 MHz

## USI



### MA-40

40' Tubular Tower

REG. \$1205.00  
SALE \$999.95

### MA-550

55' Tubular Tower  
Handles 10 sq. ft. at 50mph  
Pleases neighbors with tubular streamlined look

Reg. \$1868.00  
SALE \$1569.95

### TX-455

55' Freestanding Crank-Up  
Handles 18 sq. ft. @ 50 mph  
No guying required  
Extra-strength const. Can add raising and motor drive acces.

Towers Rated to EIA Specifications  
Other Models at Great Prices!

Reg. \$2098.00  
SALE \$1699.95

Buy From HRO, World's Largest U.S. Tower Dealer

All US Towers shipped by truck; freight charges additional

## CALL TOLL FREE

Phone Hours: 9:30 AM - 5:30 PM  
Store Hours: 10:00 AM - 5:30 PM  
Closed Sun.

Toll free incl. Hawaii, Alaska, Canada. Call routes to nearest store; an HRO 800-line can assist you. If the first line you call is busy, you may call another.

West.....800-854-6046  
Mountain.....800-444-9476  
Southeast.....800-444-7927  
Mid-Atlantic.....800-444-4799  
Northeast.....800-644-4476  
New England.....800-444-0047

Look for the HRO Home Page on the World Wide Web  
<http://www.hamradio.com>

AZ, CA, CO, GA, VA residents add sales tax. Prices, specifications, descriptions, subject to change without notice.

**ANAHEIM, CA**  
(Near Disneyland)  
933 N. Euclid St., 92801  
(714) 533-7373  
**(800) 854-6046**  
Janet, KL7MF, Mgr.  
anaheim@hamradio.com

**BURBANK, CA**  
2416 W. Victory Bl., 91506  
(818) 842-1786  
**(800) 854-6046**  
Eric, KA6IHT, Mgr.  
Victory Blvd. at Buena Vista  
1 mi. west I-5  
burbank@hamradio.com

**OAKLAND, CA**  
2210 Livingston St., 94606  
(510) 534-5757  
**(800) 854-6046**  
Mark, W7YN, Mgr.  
I-880 at 23rd Ave. ramp  
oakland@hamradio.com

**SAN DIEGO, CA**  
5375 Kearny Villa Rd., 92123  
(858) 560-4900  
**(800) 854-6046**  
Tom, KM6K, Mgr.  
Hwy. 163 & Claremont Mesa  
sandiego@hamradio.com

**SUNNYVALE, CA**  
510 Lawrence Exp. #102  
94085  
(408) 736-9496  
**(800) 854-6046**  
Howard, KE6PWH, Mgr.  
So. from Hwy. 101  
sunnyvale@hamradio.com

**NEW CASTLE, DE**  
(Near Philadelphia)  
1509 N. Dupont Hwy., 19720  
(302) 322-7092  
**(800) 644-4476**  
Rick, K3TL, Mgr.  
RT.13 1/4 mi., So. I-295  
newcastle@hamradio.com

**PORTLAND, OR**  
11705 S.W. Pacific Hwy.  
97223  
(503) 598-0555  
**(800) 854-6046**  
Leon, N7IXX, Mgr.  
Tigard-99W exit  
from Hwy. 5 & 217  
portland@hamradio.com

**DENVER, CO**  
8400 E. Iliff Ave. #9, 80231  
(303) 745-7373  
**(800) 444-9476**  
Joe, KD0GA, Mgr.  
John, N5EHP, Mgr.  
denver@hamradio.com

**PHOENIX, AZ**  
1939 W. Dunlap Ave., 85021  
(602) 242-3515  
**(800) 444-9476**  
Gary, N7GJ, Mgr.  
1 mi. east of I-17  
phoenix@hamradio.com

**ATLANTA, GA**  
6071 Buford Hwy., 30340  
(770) 263-0700  
**(800) 444-7927**  
Mark, KJ4VD, Mgr.  
Doravilla, 1 mi. no. of I-285  
atlanta@hamradio.com

**WOODBIDGE, VA**  
(Near Washington D.C.)  
14803 Build America Dr. 22191  
(703) 643-1063  
**(800) 444-4799**  
Steve, N4SR, Mgr.  
Exit 161 I-95. So. to US 1  
woodbridge@hamradio.com

**SALEM, NH**  
(Near Boston)  
224 N. Broadway, 03079  
(603) 898-3750  
**(800) 444-0047**  
Chuck, N1UC, Mgr.  
sales@hamradio.com  
Exit 1, I-93;  
28 mi. No. of Boston  
saalem@hamradio.com